

(No Model.)

3 Sheets—Sheet 1.

C. E. ROBERTS.

MACHINE FOR MILLING NUTS.

No. 355,718.

Patented Jan. 11, 1887.

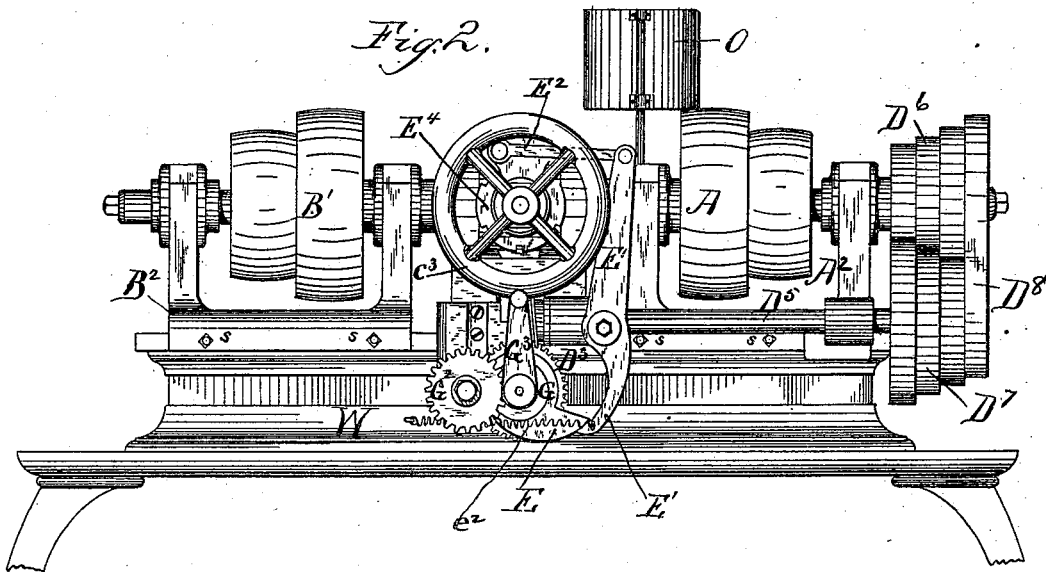
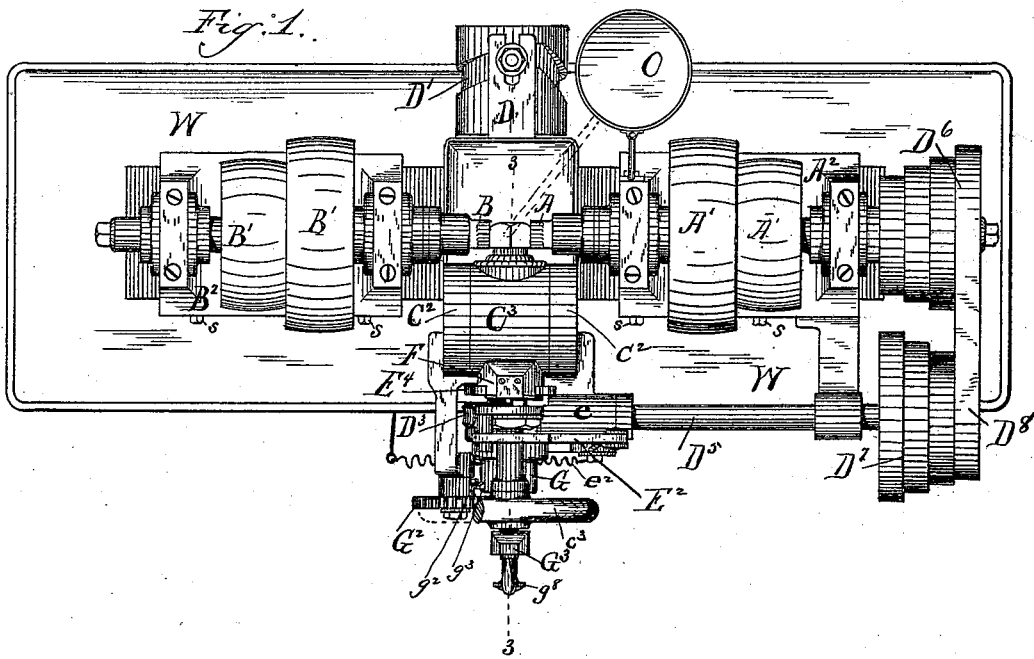

Witnesses:
 Lew. G. Curtis.
 Taylor E. Brown

Inventor:
 Chas E. Roberts
 By Munday, Evans & Adcock
 his Attorneys:

C. E. ROBERTS.

MACHINE FOR MILLING NUTS.

No. 355,718.

Patented Jan. 11, 1887.

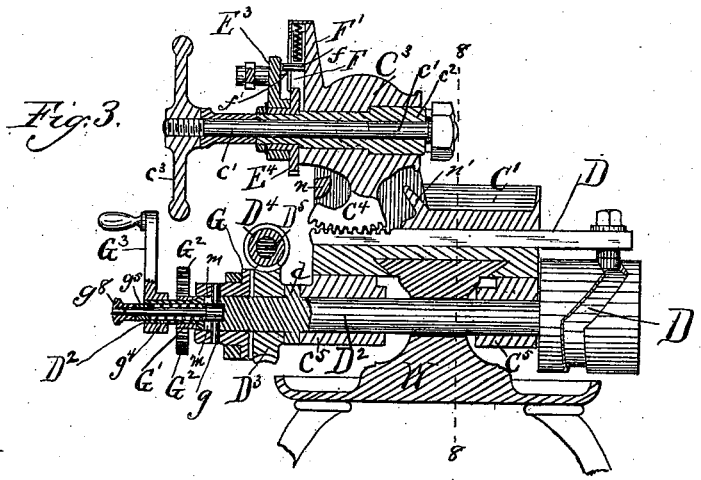

Fig. 5.

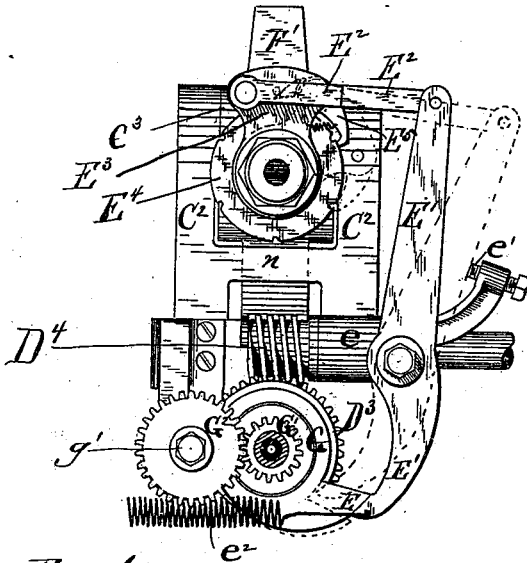

Fig. 4.

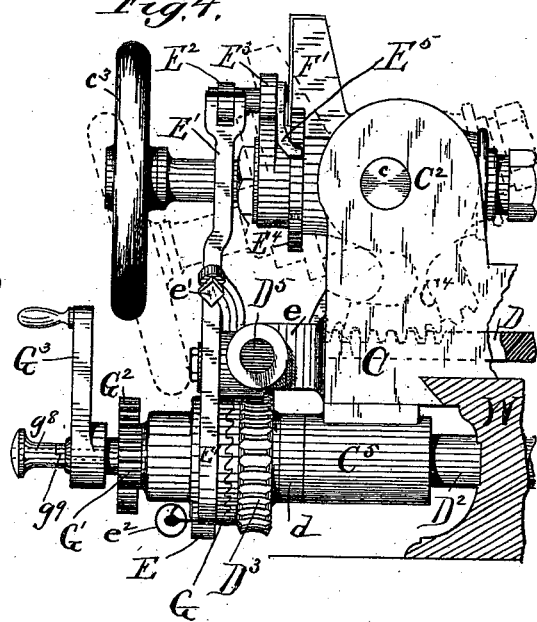

Fig. 6.

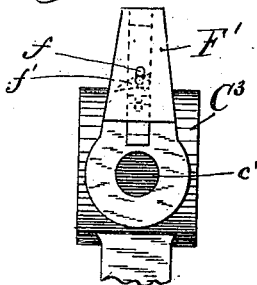
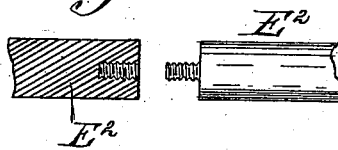

Fig. 7.



Witnesses:

Lev. G. Curtis.
Taylor & Brown

Inventor:

Chas. E. Roberts.
By Munday Evans & Adcock
his Attorneys.

C. E. ROBERTS.

MACHINE FOR MILLING NUTS.

No. 355,718.

Patented Jan. 11, 1887.

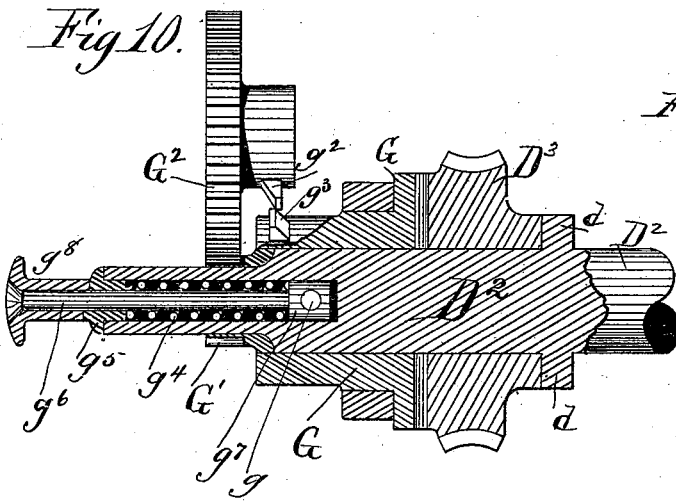
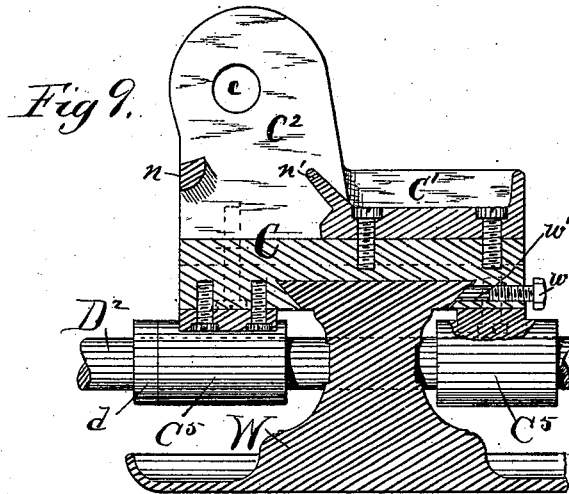
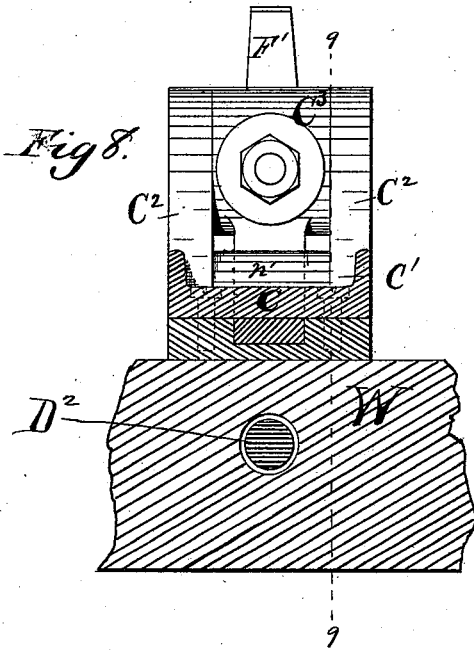
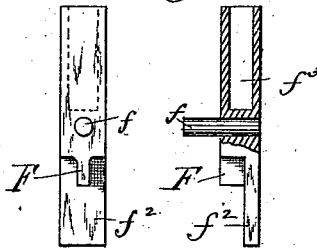

Fig. 11. Fig. 12.



Witnesses:

Lev. S. Curtis.

Saylor E. Brown

Inventor:

Chas. E. Roberts.

By Munday Evans & Adcock

his Attorneys.

UNITED STATES PATENT OFFICE.

CHARLES E. ROBERTS, OF CHICAGO, ILLINOIS.

MACHINE FOR MILLING NUTS.

SPECIFICATION forming part of Letters Patent No. 355,718, dated January 11, 1887.

Application filed September 28, 1886. Serial No. 214,725. (No model.)

To all whom it may concern:

Be it known that I, CHARLES E. ROBERTS, a citizen of the United States, residing in Chicago, in the county of Cook and State of Illinois, have invented a new and useful Improvement in Machines for Milling Nuts, of which the following is a specification.

My invention relates to machines for milling the edge faces of bolt heads and nuts, and is designed to improve the present construction of such machines.

In my improved machine I employ a pair of horizontal rotating milling-cutters placed opposite to each other, so as to operate upon opposite sides of the nut simultaneously, and a nut-holder swinging at right angles to the cutters and acting to lower the nut into the space between and in contact with the cutters. This nut-holder is mounted upon trunnions, and is swung both up and down automatically. The mechanism by which the holder is swung is the following: A toothed segment attached to the holder engages with a sliding rack operated by a cam upon a transverse shaft receiving motion through a gear and worm from a longitudinal shaft actuated from one of the driving-pulley shafts or other suitable source of power, the cam being so constructed as to slide the rack and swing the holder in both directions. I also partially rotate the nut-holder after each return swing movement, to present fresh surfaces for the next operation of the milling-cutters. For this purpose the parts by which the nut is clamped are made rotatable in the swinging head of the holder, and the rotation is caused automatically by devices which will be fully described hereinafter. I also cause the periodical rotation above mentioned to cease automatically by mechanism set forth at length in the description given below herein when the nut has been treated upon all sides. The nature of these various mechanisms and their construction and mode of operation will be understood from the drawings accompanying this specification and forming part thereof, in which—

Figure 1 is a plan of my improved machine, and Fig. 2 a front elevation thereof. Fig. 3 is a transverse section on line 3 3 of Fig. 1. Fig. 4 is a transverse section enlarged, showing the side of the nut-holding and operating devices. Fig. 5 is an enlarged front view of

the parts illustrated in Fig. 4, the hand-wheel being left off to show the parts behind it. Figs. 6 and 7 are enlarged detail views of portions of the machine. Fig. 8 is an enlarged section upon the line 8 8 of Fig. 3. Fig. 9 is an enlarged vertical section through the nut-rest upon the line 9 9 of Fig. 8. Fig. 10 is an enlarged horizontal section through the clutching devices for operating and stopping the rotation of the nut. Figs. 11 and 12 are detail views of the spring-bolt, whereby the nut-holder is locked against rotation during the milling operations.

In said drawings, W represents the bed of the machine, the upper surface thereof acting also as a slideway, upon which the cutter-carrying head-stocks and the nut-holding devices may be moved longitudinally and adjusted as occasion requires.

A and B are each rotating milling tools or cutters having a common axial line and placed with their operating ends toward each other, so they may operate simultaneously upon opposite sides of the nut. They are respectively operated by pulleys A' B', mounted in head-stocks A² B².

C represents a saddle sliding upon the bed W, and held thereto by the bolt *w* and shoe *w'*. Upon this saddle is secured, as shown in Fig. 9, a casting, embodying a pan, C', to receive the cuttings from the milling, and side cheeks, C² C². In the latter the nut-holding devices now to be described are supported by the trunnions *c*, resting in bearings *c*¹. The nut, preparatory to being milled, is threaded upon the end of a rod, *c'*, extending through a sleeve, *c*², and the rod, after being adjusted, is clamped so as to be immovable in the sleeve by turning the hand-wheel *c*², which is threaded upon the opposite end of said rod *c'*. The sleeve *c*² is free to rotate in the head C³, and the latter oscillates upon the trunnions *c* and carries the nut down into contact with the milling-tools and back again after it has been operated upon. This oscillation is caused by the reciprocation of a rack-bar, D, which engages a depending toothed segment, C⁴, formed upon or attached to the head C³, the rack-bar being reciprocated by a grooved cam, D', upon the end of a transverse shaft, D², supported in bearings C⁵, attached to the saddle C and passing through the bed W. The parts C C² C² and C³

make up what may be appropriately termed the "nut-rest" in analogy to the tool-rest of an ordinary lathe.

The shaft D^2 is provided with a rigid collar, d , by which and the cam D' it is held firmly against end play, the collar setting up against the shaft-bearing upon one side and the cam setting up against the bearing upon the other side. The shaft is actuated through the worm-wheel D^3 , loose upon said shaft and having a clutch side face, the sliding clutch G , keyed to the shaft by the pin g , but sliding thereon and engaging with the clutch-face of gear D^3 , the worm D^4 upon the shaft D^5 and meshing with the worm-wheel D^3 , and the shaft D^5 , receiving power from the shaft of pulley A' through pulleys D^6 and D^7 and a connecting-belt, D^8 .

Between the oscillations of the head C^3 the rod c' and sleeve c^2 are partially rotated to present other surfaces of the nut for the next milling operation. This movement is caused as follows: The cam E upon the clutch G engages at every revolution with a swinging lever, E' , pivoted upon the bracket e and connected by a jointed arm, E^2 E^2 , with a swinging arm, E^3 , mounted upon the sleeve c^2 or upon the hub of the ratchet-wheel E^4 , and operating said wheel intermittently by means of a pawl, E^5 , borne by the arm E^3 . The return movement of the lever, which is caused by the spring e^2 and is a quick one, carries the ratchet-wheel with it by the engagement therewith of the pawl. In Fig. 5 this engagement of the wheel and pawl will take place in the notch just above the pawl before the cam has ceased its action upon the lever E' . A set-screw, e' , serves to limit the return swing, and the pawl is preferably influenced by a spring, as shown.

The parts composing the jointed arm E^2 E^2 are coupled together by a male and female screw-joint, (particularly illustrated in Fig. 7,) one part being thereby permitted to twist upon the other, to accommodate the swinging of the head C^3 without affecting the ability of the arm to perform all its functions.

The ratchet-wheel is locked between its rotary movements by a spring-bolt, F , secured in a housing, F' , upon the head C^3 , and entering the peripheral spaces in the wheel E^4 . A pin, f , secured in the bolt, projects through the housing, and an inclined-surfaced projection, f' , upon the arm E^3 comes in contact therewith at each forward swing of said arm E^3 , and raises said bolt, thereby releasing the wheel, so it can rotate with the pawl E^5 . The form of this bolt is more particularly set forth in the detail views, Figs. 11 and 12, the leg f^2 thereof serving as a guide in its movements. The cavity f^3 holds the spring by which the bolt is depressed.

For the purpose of causing a cessation of the rotary movements of the nut when it has been milled upon all sides, the sliding clutch G is thrown out of engagement with the gear D^3 at proper intervals. This is done by means of the following devices: The shaft D^2 is continued to the front of the machine, and has

mounted thereon a pinion, G' . The pinion G' meshes with another pinion, G^2 , which bears a certain relation in the matter of size to the pinion G' , depending upon the number of sides possessed by the nut being milled. Thus, in the drawings, the nut operated upon being six-sided, and requiring to be placed in three positions for milling all its sides, the pinion G^2 is made three times the size of pinion G' . If the number of sides upon the nut is greater or less than six, then the relative difference in size of the pinions is made greater or less accordingly. The pinion G^2 is journaled upon a pivot, g' , projecting from a stationary part of the machine, and bears upon its hub an inclined-surfaced projection, g^2 , which at each revolution of pinion G^2 , and each third revolution of the pinion G' and its shaft D^2 , strikes a like projection, g^3 , upon the hub of the sliding clutch G . The colliding of these projections g^2 and g^3 forces the sliding part of the clutch out of engagement with the gear D^3 , and as the opening of the clutch withdraws power from the part G , that part and the shaft D^2 at once stop, and no further movement of the nut, either oscillatory or rotary, takes place until the clutch is closed again.

The clutch is kept open by the parts g^2 and g^3 until the finished nut has been replaced by a fresh one, and then the operator turns the crank or hand wheel G^3 until said parts have passed each other, and the clutch is then closed by the spring g^4 , confined in the hollow end of the shaft D^2 , between the ring g^5 and the pin g . The machine then proceeds as before, milling the nut upon all sides and stopping automatically when done.

As it is sometimes desirable to stop the oscillation or rotation of the nut at unexpected times, I have provided means for that purpose, consisting of a rod, g^6 , secured in the hub g' upon the pin g and extending through and beyond the ring g^5 , and furnished with a knob, g^8 , capable of turning thereon, and having a cam, g^9 , formed upon its rim bearing against the correspondingly-shaped rim of said ring. This device is operated by the workman, who takes hold of the knob and detains it from rotation for an instant, while the ring continues in motion, thereby causing these parts to separate, and in so doing to draw the parts of the clutch G D^3 apart also. The same spring g^4 will close the clutch G D^3 whenever the knob g^8 is turned again to close its own clutch with the ring g^5 .

The spaces m in the shaft D^2 permit the sliding of the clutch by giving room for the movement of pin g . The cheeks C^2 C^2 are connected and supported by the ribs nn' , the latter forming one side of the pan C' . The head-stocks may be secured upon the bed by set-screws ss , or they may be held and adjusted in the same manner as the tail-blocks and tool-rests of lathes. The oil is supplied to the milling-tools from the reservoir O .

By employing two milling-tools placed exactly opposite to each other and acting simul-

taneously upon opposite sides of the nut, the pressure exerted by one upon the nut is largely neutralized by the pressure of the other, thereby relieving the holding devices in some measure. The opposite sides of the nut thus treated are more apt to be exactly parallel than when one side is milled at a time.

I claim—

1. The combination, in a nut-milling machine, of a pair of rotating milling-cutters placed opposite to each other, and a nut-holding head automatically swinging at intervals past the cutters and back again, and the devices for so actuating the head, substantially as set forth.

2. The combination, with the rotating milling-tools operating upon opposite sides of the nut, of holding devices for the nut having intermittent oscillating and rotating movements, substantially as specified.

3. The cutters, the intermittently-oscillating head, and the intermittently-rotating nut-holder supported in said head, all combined and operating substantially as specified.

4. The cutters, the oscillating head, mechanism for intermittently actuating said head, the rotatable nut-holder, and mechanism for intermittently actuating said holder, all combined and operating substantially as specified.

5. In a machine for milling nuts, the combination, with the oscillating head for carrying the nut, the mechanism for intermittently oscillating such head, and the actuating-shaft D^2 , of a clutch-connection between said oscillating mechanism and said actuating-shaft, substantially as set forth.

6. In a machine for milling nuts, the oscillating head, mechanism for intermittently oscillating said head, the rotatable nut holder, and mechanism for intermittently rotating the same, in combination with the actuating-shaft D^6 and a clutch-connection with said shaft, substantially as set forth.

7. In combination with the mechanism for intermittently rotating the nut, a clutch for carrying power to said mechanism, and mechanism for opening said clutch timed to operate at stated intervals with respect to the rotating movements of the nut, substantially as specified.

8. In combination with the mechanism for intermittently rotating the nut and the mechanism for intermittently operating the head which carries the nut to the cutters, a clutch for carrying power to said mechanisms, and mechanism for opening said clutch timed to operate at intervals, substantially as specified.

9. In combination with the mechanism for intermittently rotating the nut, a clutch for carrying power to said mechanism, mechanism for opening said clutch timed to operate at stated intervals with respect to the rotating movements of the nut, and the crank G^3 for closing said clutch at will, substantially as specified.

10. In combination with the nut holding and operating devices and the mechanism for

operating the same, a clutch for carrying power to the latter and mechanism for operating said clutch at will, substantially as specified.

11. The combination, with the cutters, of nut holding and moving devices consisting of an intermittently-oscillating head, a rod threaded at one end to receive the nut, a sleeve surrounding the rod, and a hand-wheel, the rod, sleeve, and wheel being jointly rotatable in the head, substantially as set forth.

12. The rod having the threaded end to receive the nut, the sleeve surrounding the rod, and the hand-wheel threaded upon the other end of the rod and adapted to clamp the nut against the sleeve, all supported in and in combination with the head moving to carry the nut to the cutters, substantially as specified.

13. In a nut-milling machine, the head carrying the nut and its clamping devices and having the toothed segment, in combination with the rack-bar meshing with said segment and cam for sliding said bar, substantially as specified.

14. In a nut-milling machine, the intermittently-oscillating head for moving the nut to and from the cutters, the toothed segment, the sliding rack-bar, the cam for actuating the bar, the nut-clamping devices intermittently rotatable in said head, the ratchet-wheel, the pawl, the arm carrying said pawl, the jointed arm E^2 , the pivoted lever, and the cam actuating said lever, in combination with the shaft D^2 , both said cams being mounted upon said shaft, substantially as specified.

15. The saddle C , the shaft D^2 , supported in bearings C^5 , secured to said saddle and having a collar, d , the cam D' , mounted upon said shaft, and worm-wheel D^3 , also on said shaft, all combined, arranged, and constructed as set forth.

16. The combination, with the ratchet wheel operating the nut-holder rod and sleeve, of the bolt F , having the pin f , the swinging arm E^3 , having the inclined surface f' , acting upon said pin, and the pawl E^5 , also carried by said arm, substantially as specified.

17. In combination with the intermittently-rotating nut-holder supported in a swinging head, the jointed arm E^2 , and a lever actuating said arm, substantially as specified.

18. In combination with the clutch G , the rod g^6 , attached to the sliding part G , the handle g^8 , ring g^5 , and shaft D^2 , substantially as specified.

19. In combination with the nut-holder, the cam E , lever E' , link E^2 , arm E^3 , pawl E^5 , wheel E^4 , and spring e^2 , substantially as specified.

20. In combination with the spring e^2 , lever E' , link E^2 , arm E^3 , pawl E^5 , and wheel E^4 , substantially as specified.

21. In a nut-milling machine, the combination of continuously-rotating cutters, the continuously-rotating worm D^4 , the gear D^3 , meshing with said worm, a head for carrying the nut to the cutters, mechanism for actuating said head, a clutch for carrying power from said worm to said head, actuating mechanism,

means for closing said clutch at pleasure, and means for releasing it automatically, substantially as specified.

22. The supporting sides C² C², for supporting the nut-carrying head, and the pan C', cast in one piece, substantially as specified.

23. The nut-rest consisting of the saddle C,

the side pieces, C² C², the head for carrying the nut to the cutters, and the clamping devices for holding the nut, substantially as specified. 10

CHARLES E. ROBERTS.

Witnesses:

H. M. MUNDAY,
EDMUND ADCOCK.